

SWV40

40 LITERS STAINLESS STEEL WET/DRY VACUUM WITH PTA

OWNER'S MANUAL

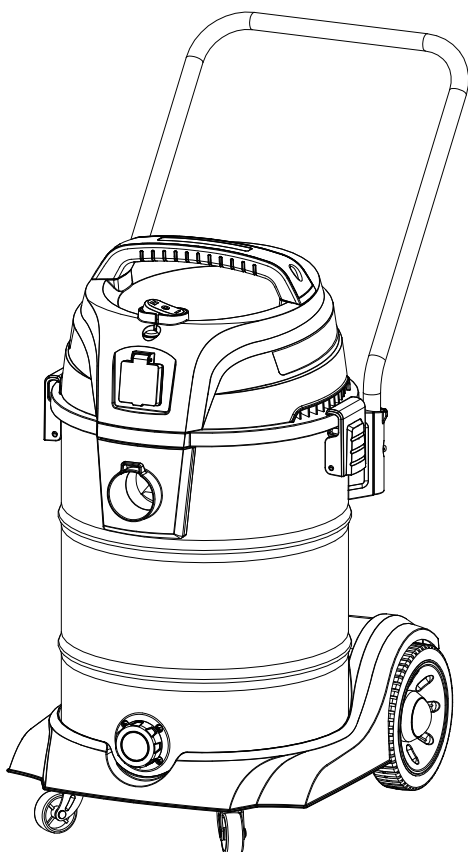

FOR YOUR SAFETY
PLEASE READ THESE INSTRUCTIONS CAREFULLY
AND RETAIN THEM FOR FUTURE USE.



PACKAGE CONTENTS

DEFINITIONS: SAFETY ALERT SYMBOLS AND WORDS

This instruction manual uses the following safety alert symbols and words to alert people to hazardous situations and the risk of personal injury or property damage.

- ⚠ DANGER:** Indicates an imminently hazardous situation which, if not avoided, will result in death or serious injury.
- ⚠ WARNING:** Indicates a potentially hazardous situation which, if not avoided, could result in death or serious injury.
- ⚠ CAUTION:** Indicates a potentially hazardous situation which, if not avoided, may result in minor or moderate injury.
- NOTICE:** Indicates a practice not related to personal injury which, if not avoided, may result in property damage.

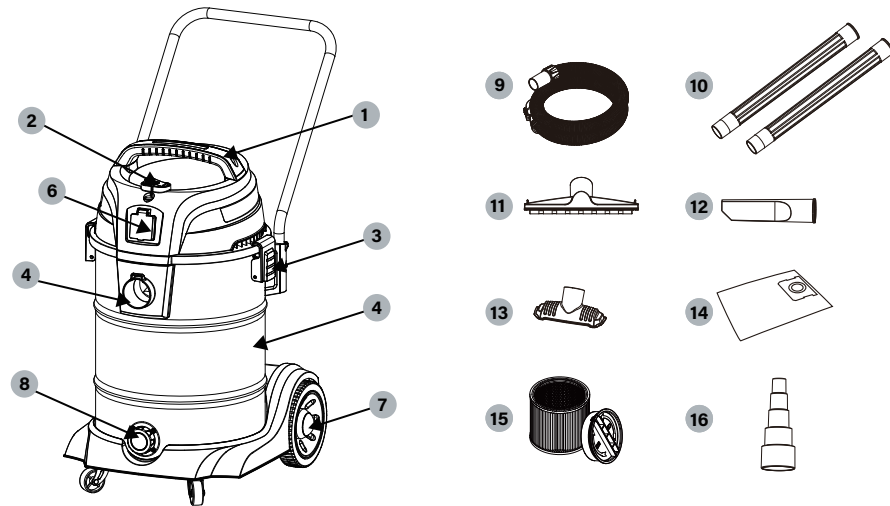

- | | |
|------------------------------|--|
| 1 Handle | 11 Floor nozzle (19-1900) |
| 2 Power switch | 12 Crevice nozzle (19-1400) |
| 3 Lid latch | 13 Utility nozzle (19-1300) |
| 4 Vacuum port | 14 Disposable filter bag (19-3100N) - For dry pick up only |
| 5 Dust tank | 15 Cartridge filter (08-2566) - For wet/dry pick up |
| 6 Power tool socket | 16 Universal adapter (15-1000) |
| 7 Wheel | |
| 8 Drain port | |
| 9 48mm x 2.5m Hose (19-1108) | |
| 10 Extension wand (19-1200) | |

⚠ WARNING: Read all safety warnings and all instructions. Failure to follow the warnings and instructions may result in electric shock, fire and/or serious injury.

⚠ WARNING: To reduce the risk of injury, read the instruction manual.

GENERAL SAFETY PRECAUTIONS

IMPORTANT SAFETY INSTRUCTIONS

⚠ WARNING: When using electrical appliances, always follow basic safety precautions to reduce the risk of fire, electric shock and personal injury, including the following:

BEFORE USING THIS APPLIANCE, READ AND FOLLOW ALL INSTRUCTIONS.

- ⚠ WARNING:** To reduce the risk of electric shock. Do not expose to rain. Store indoors.
- Do not leave the appliance when it is connected to a power source. Unplug it from outlet when not in use and before servicing.
- Do not allow the appliance to be used as a toy. Pay close attention when the appliance is used by or near children.
- Do not use this appliance ONLY as described in the manual. Use only SGS recommended attachments.
- Do not use this appliance with a damaged cord or plug. If the appliance is not working correctly, or if it has been dropped, damaged, left outdoors, or dropped in water, return it to a service center.
- Do not pull or carry this appliance by the cord, use the cord as a handle, close a door on the cord, or pull the cord around sharp edges or corners. Do not run the appliance over the cord. Keep cord away from heated surfaces.
- Do not unplug this appliance by pulling on the cord. To unplug, grasp the plug, not the cord.
- Do not handle the plug or appliance with wet hands.
- Do not put any objects into the openings of the appliance. Do not use the appliance with any opening blocked; keep free of dust, lint, hair and anything else that may reduce air flow.
- Keep hair, loose clothing, fingers, and all body parts away from the openings and moving parts.
- Turn off all controls before unplugging appliance.
- Take extra care when cleaning on stairs.
- Do not use the appliance to pick up flammable or combustible liquids, such as gasoline, or use in areas where flammable or combustible liquids are present.
- Static shocks are possible in dry areas or when the relative humidity of the air is low. This is only temporary and does not affect the use of the vacuum. To reduce the frequency of static shocks, add moisture to the air with a console, installed humidifier or use anti-static hose (standard on some models).
- To avoid spontaneous combustion, empty the dust tank after each use.

SAVE THESE INSTRUCTIONS ADDITIONAL SAFETY RULES

- ⚠ WARNING**
 - Do not pick up anything that is burning or smoking, such as cigarettes, matches, or hot ashes.
 - Do not use to vacuum combustible explosive materials, such as coal, grain, or other finely divided combustible materials.
 - Do not use to vacuum hazardous, toxic or carcinogenic materials, such as asbestos or pesticide.
 - Never pick up explosive liquids (e.g. gasoline, diesel fuel, heating oil, paint thinner, etc.), acids or solvents.
 - Do not use vacuum without filters in place.
 - Some wood contains preservatives which can be toxic. Take extra care to prevent inhalation and skin contact when working with these materials. Request and follow any safety information available from the material supplier.
 - Do not use vacuum as a step ladder.
 - Do not place heavy objects on vacuum.
- ⚠ WARNING:** This product is NOT to be used for filtering of pathogens, for example COVID-19. Follow all local, state and federal guidance on general cleaning practices.
- ⚠ WARNING:** Always wear proper personal hearing protection during use. Under some conditions and duration of use, noise from this product may contribute to hearing loss.

⚠ WARNING: Always use safety goggles. Everyday eyeglasses are NOT safety goggles. Also use face or dust mask if area of operation is dusty. ALWAYS WEAR CERTIFIED SAFETY EQUIPMENT.

To reduce the exposure to these chemicals, wear approved safety equipment such as dust masks that are specially designed to filter out microscopic particles.

⚠ WARNING: If the supply cord is damaged, it must be replaced by the manufacturer or its service agent or a similarly qualified person in order to avoid a hazard.

GENERAL SAFETY PRECAUTIONS

IMPORTANT: Remove the plug from the socket before performing maintenance. Before using the machine make sure that the frequency and voltage shown on the rating plate correspond with the mains voltage. Specifications and details are subject to change without prior notice. The accessories shown in the pictures may vary from model to model.

SAVE THESE INSTRUCTIONS GROUNDING INSTRUCTIONS

This appliance must be grounded. If it should malfunction or breakdown, grounding provides a path of least resistance for electric current to reduce the risk of electric shock. This appliance is equipped with a cord having an equipment-grounding conductor and grounding plug. The plug must be inserted into an appropriate outlet that is properly installed and grounded in accordance with all local codes and ordinances.

WARNING
IMPROPER CONNECTION OF THE EQUIPMENT-GROUNDING CONDUCTOR CAN RESULT IN A RISK OF ELECTRIC SHOCK. CHECK WITH A QUALIFIED ELECTRICIAN OR SERVICE PERSON IF YOU ARE IN DOUBT AS TO WHETHER THE OUTLET IS PROPERLY GROUNDED. DO NOT MODIFY THE PLUG PROVIDED WITH THE APPLIANCE - IF IT WILL NOT FIT THE OUTLET HAVE A PROPER OUTLET INSTALLED BY A QUALIFIED ELECTRICIAN.

This appliance is for use on a nominal 230-volt circuit, and has a grounded plug that looks like the plug illustrated in sketch A. A temporary adaptor that looks like the adaptor illustrated in sketches B and C may be used to connect this plug to a 2-pole receptacle as shown in sketch B if a properly grounded outlet is not available. The temporary adaptor should be used only until a properly grounded outlet (sketch A) can be installed by a qualified electrician. The green colored rigid ear, plug or the like extending from the adaptor must be connected to a permanent ground such as a properly grounded outlet box cover. Whenever the adaptor is used, it must be held in place by a metal screw.

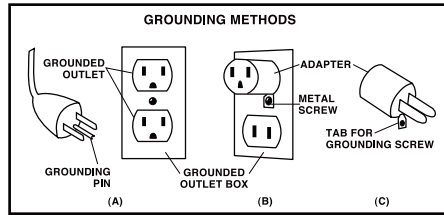

WARNING: IF THE CORD IS DAMAGED, IT MUST BE REPLACED BY A SPECIAL CORD OR SERVICE AGENT.

IMPORTANT SAFEGUARDS

The symbol on the product or packaging indicates that the product must not be treated as domestic refuse. Instead, it should be handed in to a collection point for the recycling of electrical and electronic components. By ensuring the product is treated in the correct manner, you will help prevent any negative impact on the environment and health that might arise were the product to be discarded as ordinary refuse. For further information about recycling, you should contact your local authorities, refuse collection service or the sales outlet where you bought the goods.



WARNING

- TO REDUCE THE RISK OF INJURY, USERS MUST READ INSTRUCTION MANUAL. DO NOT RUN UNATTENDED. DO NOT PICK UP FLAMMABLE, COMBUSTIBLE OR HOT MATERIALS. DO NOT USE AROUND EXPLOSIVE DUST, LIQUIDS OR VAPORS. ELECTRICAL DEVICES PRODUCE ARCS OR SPARKS WHICH CAN CAUSE FIRE OR EXPLOSION. DO NOT USE AT FILLING STATIONS OR ANYWHERE GASOLINE IS STORED OR DISPENSED. DO NOT VACUUM TOXIC OR CARCINOGENIC MATERIALS OR OTHER HEALTH ENDANGERING MATERIALS SUCH AS ASBESTOS OR PESTICIDES. ALWAYS USE PROPER EYE AND RESPIRATORY PROTECTION. TO REDUCE THE RISK OF ELECTRICAL SHOCK, DO NOT EXPOSE TO RAIN. STORE INDOORS. WHEN SERVICING, USE ONLY IDENTICAL REPLACEMENT PARTS. DO NOT TO BE USED AS A STEP STOOL.

PRODUCT SPECIFICATIONS & OPERATING INSTRUCTIONS

PRODUCT SPECIFICATIONS

Model	SWV40
Tank capacity	40L
Power	220-240V 50/60Hz 1400W
Motor	Single Stage
Hose	48mm x 2.5m
Power cord	H05VV-F 3C*1.5mm ² x 5.5m

SAVE THESE INSTRUCTIONS OPERATING INSTRUCTIONS UNPACKING & SETUP SUMMARY

1. Pull lid latches in an outward motion, remove power head and some accessories that may have been shipped in the tank.
2. Attach accessories following the instructions in this manual.
3. Before replacing power head, refer to this manual to ensure you have the proper filter installed for the cleaning operation.
4. Replace power head, and apply pressure with thumb to each latch until it snaps tightly in place. Make sure all lid latches are clamped securely.
5. Insert the hose end into inlet of tank.
6. Attach the extension wands to the end of the hose. Apply slight pressure until fitting is tight.
7. Attach one of the cleaning accessories (depending on the cleaning requirements) to the extension wands. Twist slightly to tighten the connection.
8. Plug the cord into the wall outlet. The vacuum is ready for use.
9. Turn the unit "ON" by pushing the switch position with (I), When needing to connect the power tool to use, please turn the unit "ON" by pushing the switch position with (II).

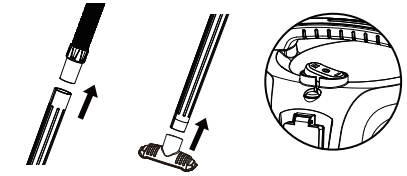
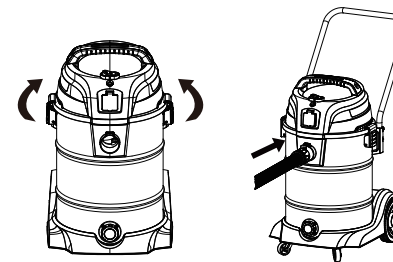

WARNING: To reduce the risk of injury from accidental starting, always shut off vacuum and disconnect the power plug from the wall outlet before installing any part or cleaning accessory.

WARNING: Do not alter the plug in any way. If the plug does not fit fully in the outlet, reverse the plug. If it still does not fit, contact a qualified electrician to install the proper outlet.

WARNING: To reduce the risk of fire or explosion, do not operate this vacuum in areas with flammable gases, vapors or explosive dust in the air. Flammable gases or vapors include but are not limited to: lighter fluid, solvent-type cleaners, oil-based paints, gasoline, alcohol or aerosol sprays. Explosive dusts include but are not limited to: coal, magnesium, aluminum, and grain or gun powder. Do not vacuum explosive dust, flammable or combustible liquids or hot ashes. Do not use this vacuum as a sprayer for any flammable or combustible liquid. To reduce the risk of health hazards from vapors or dusts, do not vacuum toxic materials.

CAUTION: To reduce risk of hearing damage, wear ear protectors when using the vacuum for extended hours or when using it in a noisy area.

CONNECTING POWER TOOL

WARNING: Observe the maximum connected loads for the appliance socket (Refer to the SPECIFICATIONS.) Make sure that both the cleaner and the electric power tool are switched off before connecting or disconnecting. Connecting the power tool to the cleaner with both of them being switched on may cause unexpected and sudden start resulting serious personal injury.

OPERATING INSTRUCTIONS

CAUTION: Never connect an electric power tool with an input power exceeding that specified in the "SPECIFICATIONS" to the socket of the cleaner by turning the suction force adjusting knob. Connecting the electric power tool exceeding the specified input power may cause overheat and damage to the cleaner. Refer to the specifications to avoid this.

To connect an electric power tool, open the cap and insert the power tool plug into the socket of the cleaner.

Turn the switch to the "II" position. Switching on and off of the connected electric power tool simultaneously brings the cleaner switching on and off action. The cleaner still works for a few seconds even after the electric power tool is switched off. After use, disconnect the power tool from the socket of cleaner. Switch off the cleaner after each use.

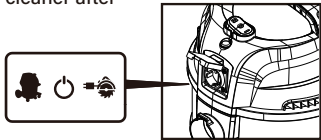

WARNING: Use the vacuum cleaner's socket outlet only for connection of an external power tool. The vacuum cleaner is automatically switched on and off via the connected power tool.

The connected load of the power tool may not exceed the maximum connected load PA of the vacuum cleaner's socket outlet. Please also observe the operating instructions and safety warnings of the power tool being connected to the socket outlet of the vacuum cleaner.

RECOMMENDATION: Always operate the vacuum cleaner via a residual current device (RCD) with a rated residual current of 200mA or less.

Please ensure that the power tool switch is in the 'Off' position before connecting the tool to the vacuum. After switching off a power tool connected to the vacuum cleaner's socket outlet, the vacuum cleaner will run on for approx. 15 seconds and then automatically switch off.

CASTER ASSEMBLY

Rear wheel and front caster assembly as follows:

1. Slide the split pin through the holes provided on the axle. Then slide the open end of axle through the gasket.

2. Place rear wheel onto axle. Be sure flat side of wheel hub is facing outward. Slide axle through holes provided in the base.
3. Slide another rear wheel onto axle, and install another pin & gasket. Insert the wheel caps into the rear wheels until wheel caps snap into place.
4. Insert casters into dolly and snap them into place.

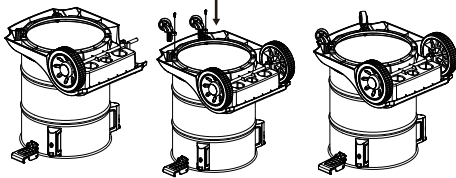

METAL HANDLE ASSEMBLY

Insert transport handle into Transport handle bracket, when you hear a click, the handle is installed. When you want to pull out the handle, use a hard object to squeeze A part inward and pull the handle up with your right hand.

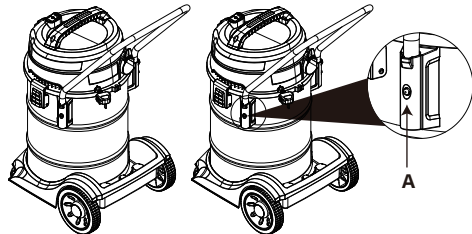

WARNING: Never operate the vacuum without filters installed.

DRY PICK-UP

INSTALLING THE DISPOSABLE FILTER BAG

1. Slide the cardboard collar opening firmly onto the vacuum port deflector until it stops against the deflector wall.
2. Position the bag so that it is distributed around the inside of the tank.

Disposable filter bag

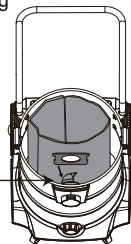

OPERATING INSTRUCTIONS

INSTALLING THE CARTRIDGE FILTER

The cartridge filter can be used for wet or dry pick-up, installation is the same for both.

1. With the power head in an upside down position, slide the cartridge filter down over the lid cage, push the filter seals against the power head.
2. Turn the knob on filter retainer clockwise to tighten, the filter into place.
3. Replace power head, and apply pressure with thumb to each latch until it snaps tightly in place. Make sure all lid latches are clamped securely.
4. Insert the hose end into inlet of tank.
5. Attach one of the cleaning accessories (depending on the cleaning requirements) on the hose. Twist slightly to tighten the connection.
6. Attach one of the cleaning accessories (depending on the cleaning requirements) to the extension wands. Twist slightly to tighten the connection.
7. Plug the cord into the wall outlet. The cleaner is ready for use.
8. Turn the unit "ON" by pushing the switch position with (I), When needing to connect the power tool to use, please turn the unit "ON" by pushing the switch position with (II).

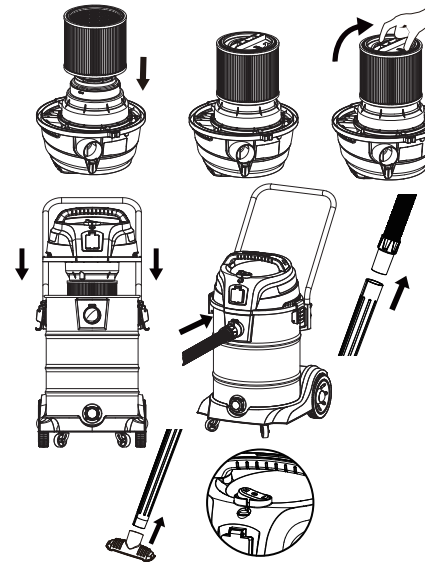

REMEMBER!

1. The filter must always be in correct position to reduce the risk of leaks and possible damage to vac. Make sure that the filter is completely covering the filter cage. Make sure there are no gaps between the filter and the lid. It is very important to assemble the filter to the cage without any possible leaks or tears. Any leaks will allow the picked up debris to be blown out of the blower port and back into the surrounding environment.
2. When using the vac to pick up fine dust, it will be necessary to empty the dust tank and clean or replace the filter at more frequent intervals to maintain peak vac performance.

NOTICE: DO NOT USE THE DISPOSABLE FILTER BAG FOR WET VACUUMING.

WET PICK-UP

UNLOAD THE CARTRIDGE FILTER

1. To remove the filter for cleaning, turn the filter knob counter clockwise till feel the tactile and auditory cue, and make sure the knob arrow align with the "Unlock" icon on the filter cap, then slide the cartridge filter off the lid cage. then grasp the step of knob tightly with fingers to pull the cartridge filter out off the cage.
2. To clean the cartridge filter, shake or brush off excess dirt or rinse with water, dry completely and re-install.
3. Replace power head, and apply pressure with thumb to each latch until it snaps tightly in place. Make sure all lid latches are clamped securely.
4. Insert the hose end into inlet of tank.
5. Attach one of the cleaning accessories (depending on the cleaning requirements) on the hose. Twist slightly to tighten the connection.
6. Attach one of the cleaning accessories (depending on the cleaning requirements) to the extension wands. Twist slightly to tighten the connection.
7. Plug the cord into the wall outlet. The cleaner is ready for use.
8. Turn the unit "ON" by pushing the switch position with (I), When needing to connect the power tool to use, please turn the unit "ON" by pushing the switch position with (II).

OPERATING INSTRUCTIONS

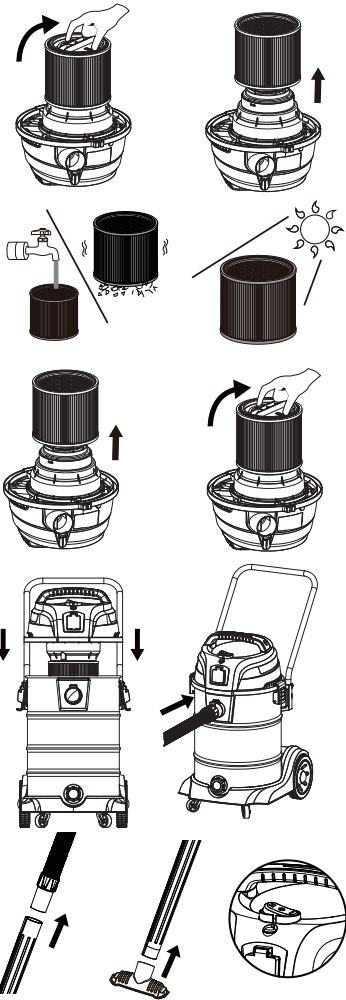

NOTICE:
WET PICK-UP ACCESSORIES SHOULD BE WASHED PERIODICALLY, ESPECIALLY AFTER PICKING UP WET, STICKY FLUIDS OR SPILLS. THIS CAN BE ACCOMPLISHED WITH A WARM SOLUTION OF SOAP AND WATER.

This wet/dry vac is equipped with a float mechanism which will rise automatically to cut off the airflow when the liquid in the tank reaches a predetermined level. When this happens, turn off vac, unplug the power cord, and empty the dust tank. You will know that the float has shut the airflow off because the suction ceases and the motor noise becomes higher in pitch due to increased motor speed. The liquid capacity may vary with the rate of pickup.

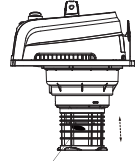

Float in raised position

IMPORTANT!

To reduce the risk of damage to the vac, do not run motor with float in raised position.

NOTICE:

IF ACCIDENTALLY TIPPED OVER, THE VACUUM COULD CLOSED SUCTION. IF THIS OCCURS, PLACE VAC IN UPRIGHT POSITION AND TURN SWITCH OFF. THIS WILL ALLOW THE FLOAT TO RETURN TO ITS NORMAL POSITION, AND YOU WILL BE ABLE TO CONTINUE OPERATION.

EMPTYING THE TANK

WARNING: To reduce the risk of injury from accidental starting, unplug power cord before emptying the dust tank.

1. Remove the power head assembly of the wet/dry vac by pulling outward on the lid clips located on each side of the vac. Lift off the power head assembly.
2. Dump the tank contents into the proper waste disposal container.
3. Liquids can be emptied through the tank drain. To empty, turn the unit off and remove the plug from the wall outlet. Remove the drain cap and deposit the liquid waste contents in a suitable drain. After tank is empty, return the drain cap to its original position. To continue use, plug the cord into the wall outlet and turn the unit on.

OPERATING INSTRUCTIONS

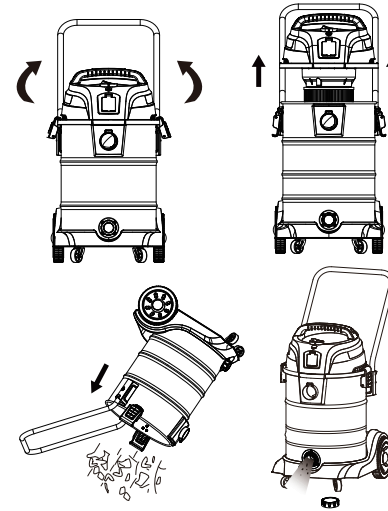

BLOWING OPERATION

WARNING: To avoid injury to bystanders, keep them clear of blowing debris.

WARNING: To avoid injury to bystanders, keep them clear of blowing debris.

CAUTION: Wear a dust mask if blowing creates dust which might be inhaled.

CAUTION: To reduce the risk of hearing loss, wear ear protectors when using the vac/blower for extended hours or when using it in a noisy area. The vac contains a blowing feature. It has the capability to blow sawdust and other debris. It can be used to blow dust and debris out of garages or off patios and driveways. Follow the steps below to use the vac as a blower.

1. Locate blower port on the vac.
2. Insert one end of the 4.8 cm x 2.5 m hose into the blower port.
3. Turn vac "ON".

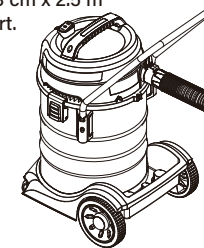

CLEANING

To keep the wet/dry vacuum looking its best, use a cloth dampened only with water and mild soap to clean its surface.

To clean the tank:

1. Dump out debris.
2. Wash tank thoroughly with a cloth dampened only with water and mild soap.
3. Wipe with dry cloth.

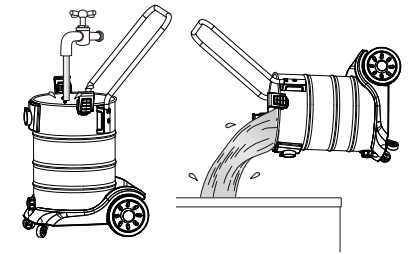

To clean the cartridge filter:

1. Shake or brush off excess dirt or rinse with water.
2. Dry completely (approximately 24 hours) and re-install.

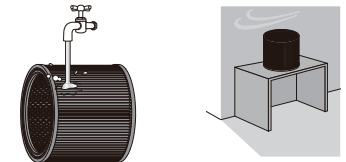

MAINTENANCE&TROUBLESHOOTING

⚠ WARNING: To reduce the risk of injury from accidental starting, unplug power cord before changing or cleaning filter. The filter should be cleaned frequently to maintain peak vacuum performance.

⚠ WARNING: Do not remove filter cage and float. The float prevents water from entering the impeller and damaging the motor. The cage prevents fingers from touching the moving impeller.

⚠ CAUTION: To avoid damage to the impeller and motor, always reinstall the reusable filter before using the vacuum for dry pickups and always reinstall the foam filter before using the vacuum for dry pickups and wet pickups.

⚠ CAUTION: After cleaning, check the filter for tears or small holes. Do not use a filter with holes or tears in it. Even a small hole can cause dust to come out of the vacuum. Replace it immediately.

⚠ CAUTION: If the filter is clean and not damaged, replace it on the filter cage. If it cannot be reused, place a new filter over the filter cage.

⚠ CAUTION: Clean the filter in an open area.

STORAGE

Before storing the vacuum, the dust tank should be emptied and cleaned. The cord should be wrapped and hung on the unit and the accessories should be kept in the accessory holder. The vacuum should be stored indoors.

TROUBLESHOOTING

⚠ WARNING: TO REDUCE THE RISK OF INJURY FROM MOVING PARTS AND/OR ELECTRICAL SHOCK, TURN POWER SWITCH OFF AND DISCONNECT GROUNDED PLUG FROM ELECTRICAL OUTLET BEFORE PERFORMING TROUBLESHOOTING CHECKS.

Minor problems often can be fixed without calling customer service.

PROBLEM	POSSIBLE CAUSE	CORRECTIVE ACTION
Vacuum does not run	No electricity	Make sure electrical outlet has voltage (A qualified electrician may need to be contacted)
Loss of suction, wet pick-up	1. Full tank 2. Clogged hose 3. Clogged filter	1. Drain and clean tank 2. Remove hose and clean debris 3. Clean or replace filter
Loss of suction, dry pick-up	1. Full tank 2. Clogged hose 3. Clogged filter	1. Drain and clean tank 2. Remove hose and clean debris 3. Clean or replace filter

EXPLODED VIEW

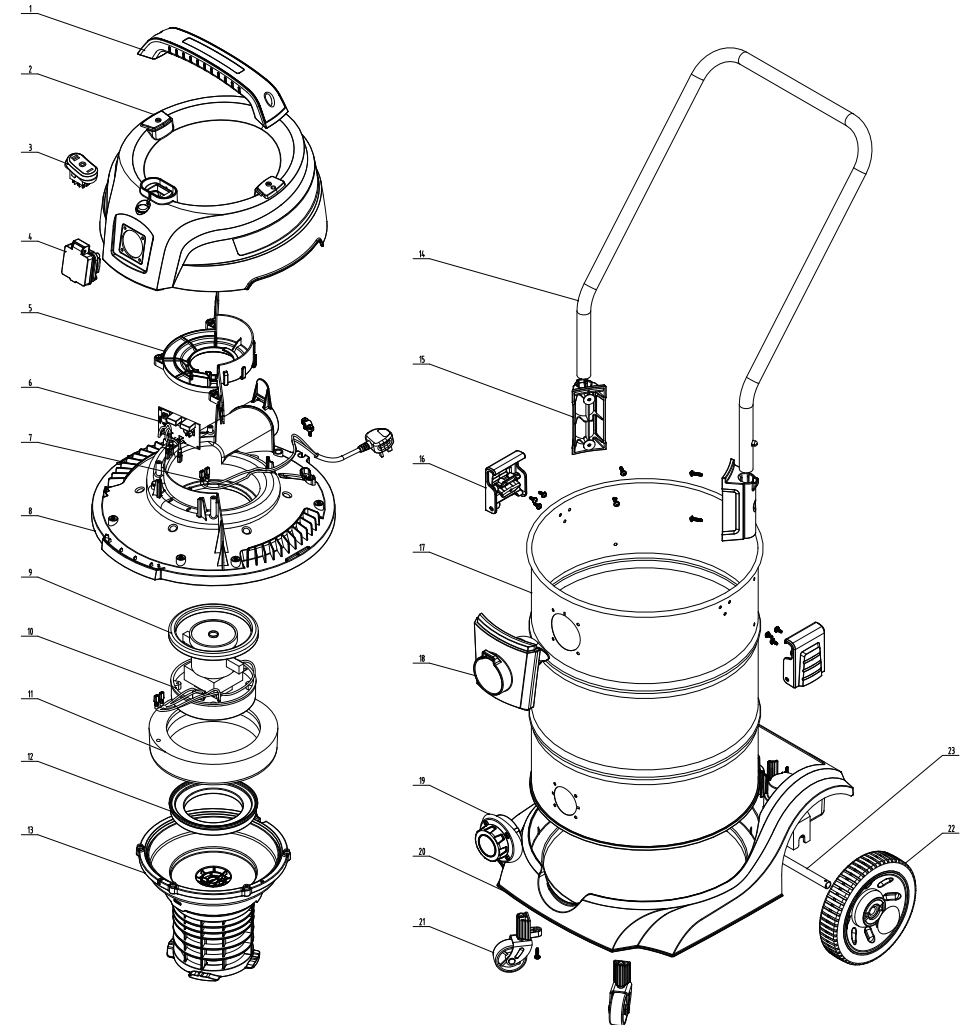

PARTS LIST

ITEM	DESCRIPTION	QTY
1	Handle	1
2	Top Cover	1
3	ON/OFF Switch	1
4	Power Tool Socket	1
5	Baffle	1
6	PCB	1
7	Power Cord	1
8	Lid	1
9	Baffle Sealing Ring	1
10	Motor	1
11	Silencer Sponge	1
12	Motor Sealing Ring	1
13	Filter Cage	1
14	Putter	1
15	Putter Seat	2
16	Lid Latch	2
17	Dust Tank	1
18	Vacuum Port	1
19	Drain Port	1
20	Caster Dolly with Accessories Holder	1
21	Caster	2
22	Wheel	2
23	Wheel Shaft	1

WARRANTY

**SGS Engineering (UK) Ltd
2 Years Limited Warranty**

This warranty covers any defects in materials or workmanship of the enclosed product. SGS Engineering (UK) Ltd will replace any defective materials due to the craftsmanship of the product. This warranty does not cover any problem caused by misuse, abuse, accidents, or acts of God, such as floods or hurricanes. Consequential and incidental damages are not covered under this warranty. Coverage terminates if you sell or otherwise transfer the ownership. If you feel you have a defective product, please return it to the store where you acquired it along with a copy of your receipt.

Address: Unit 1, West Side Park, Belmore Way,
Derby, DE21 7AZ, United Kingdom.

Telephone: 01332576850;

Support email: support@sgs-engineering.com

We will inspect the product and contact you within 72 business hours to give you the results of our inspection, we reserve the right to replace the product at our discretion. However; we may replace the product with one of the similar but not exact features.

This warranty gives you specific legal rights. You may have other rights that vary from country to country.





SGS Engineering (UK) Ltd
West Side Park
Raynesway
Derby, DE21 7AZ

EC Declaration of Conformity

This is an important document and should be retained

MANUFACTURER'S NAME: SGS Engineering (UK) Ltd

TYPE OF EQUIPMENT: WET/DRY VACUUM WITH PTA

PART NUMBER: AT19502E-10B/SWV40

APPLICATION OF EC COUNCIL DIRECTIVES / STANDARD:

2006/42/EC, EN60335-1 / EN60335-2-69

These products also comply with Directive, 2011/65/EU and
(EU) 2015/863

I, the undersigned, hereby declare that the equipment specified above conforms to the above European Communities Directive(s) and Standard(s).

PLACE: Derby, UK

DATE: 24th NOV 2023

A handwritten signature in black ink, appearing to read 'Robert Wyatt', written over a horizontal line.

(Signature)

Robert Wyatt

Company Secretary